

THE DOCUMENT AND THE DESIGN INFORMATION HEREIN IS AN INSTRUMENT OF PROFESSIONAL SERVICE IN THE PROPERTY OF ADVANTAGE GROUP ENGINEERS, INC. COPYRIGHT 2006. ADVANTAGE GROUP ENGINEERS, INC. ALL RIGHTS RESERVED.

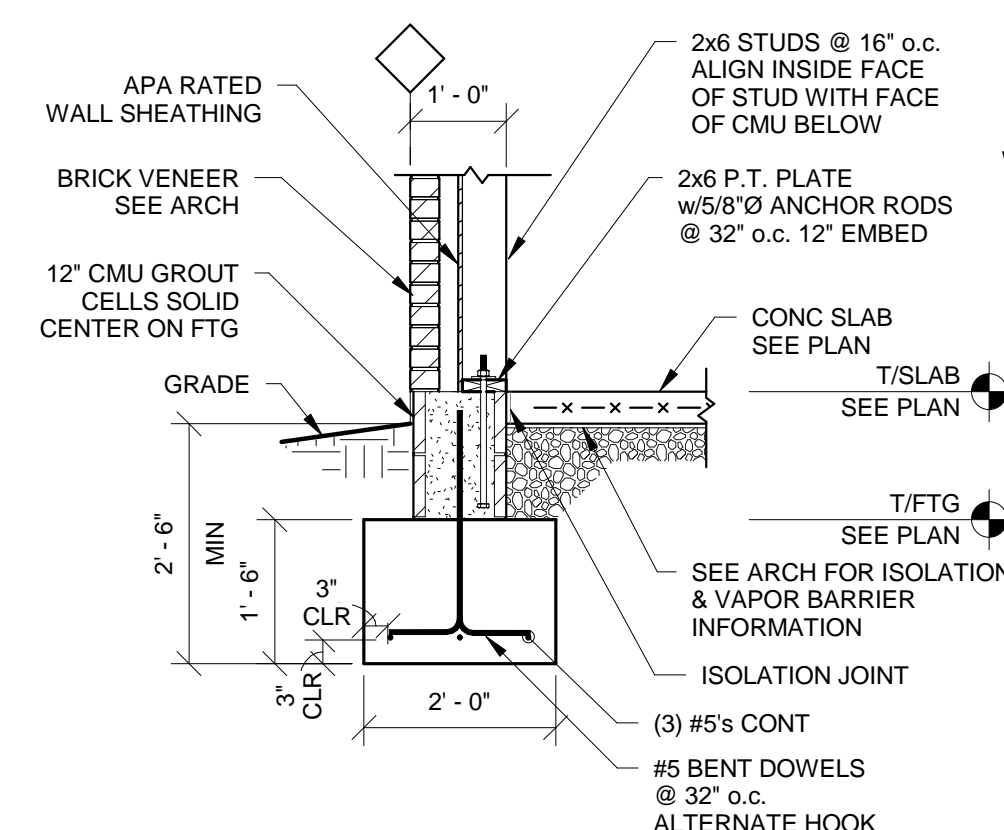

SECTION 1
SCALE 1/2" = 1'-0" S310

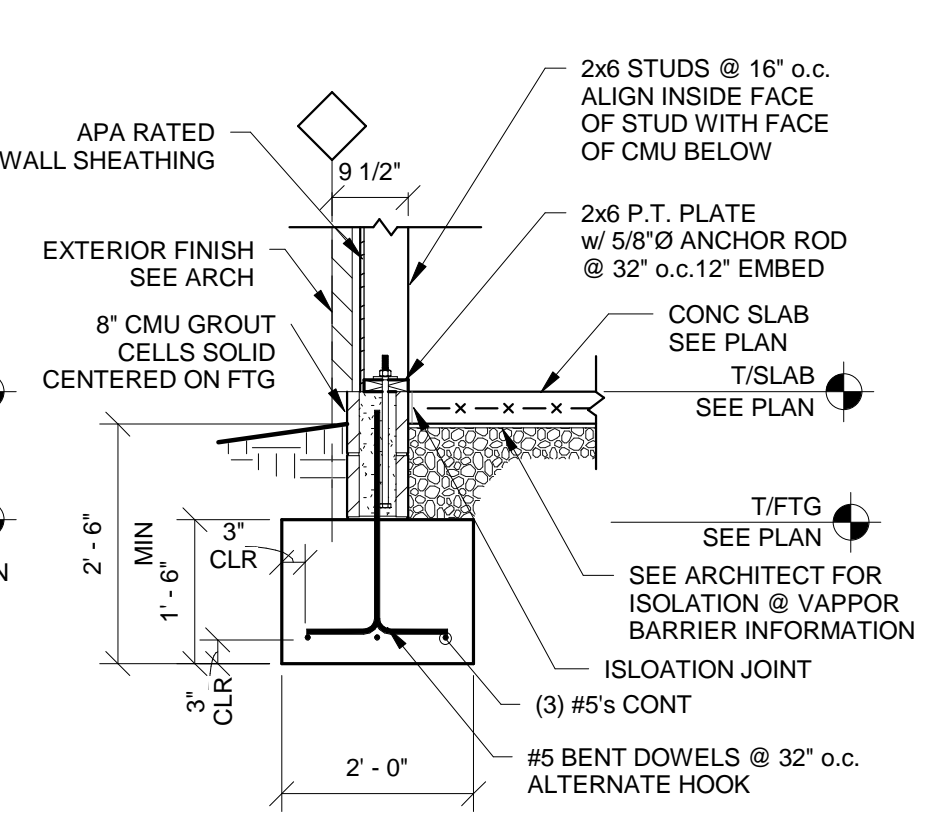

SECTION 2
SCALE 1/2" = 1'-0" S310

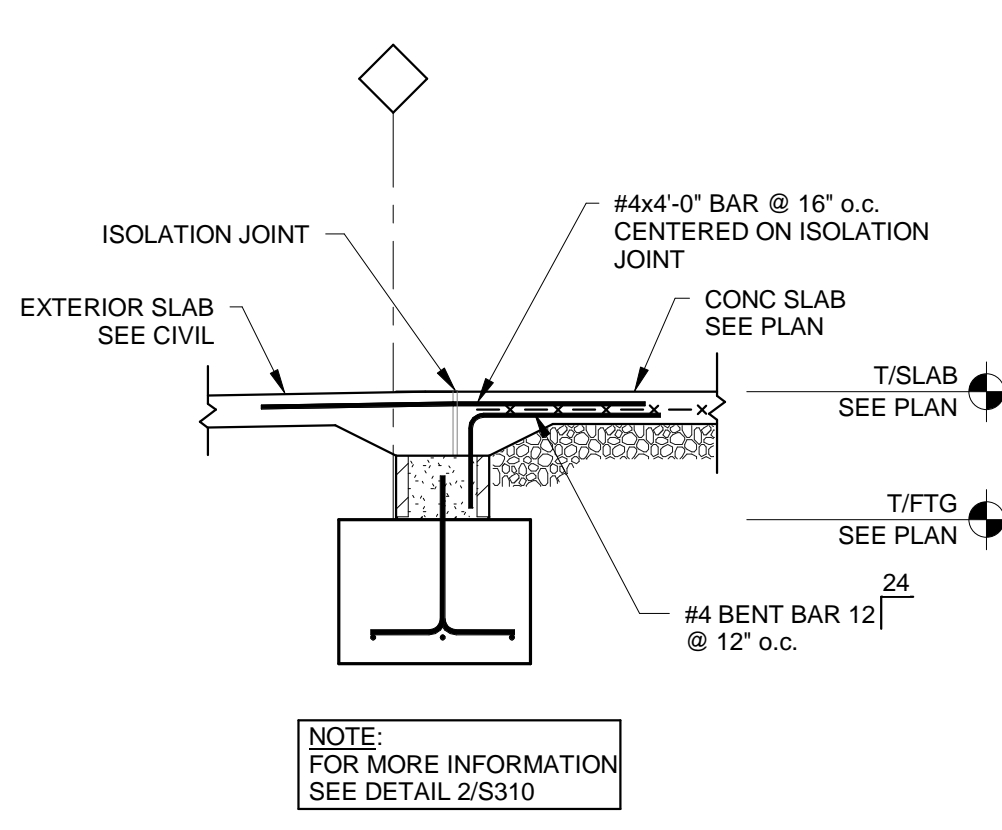

SECTION 3
SCALE 1/2" = 1'-0" S310

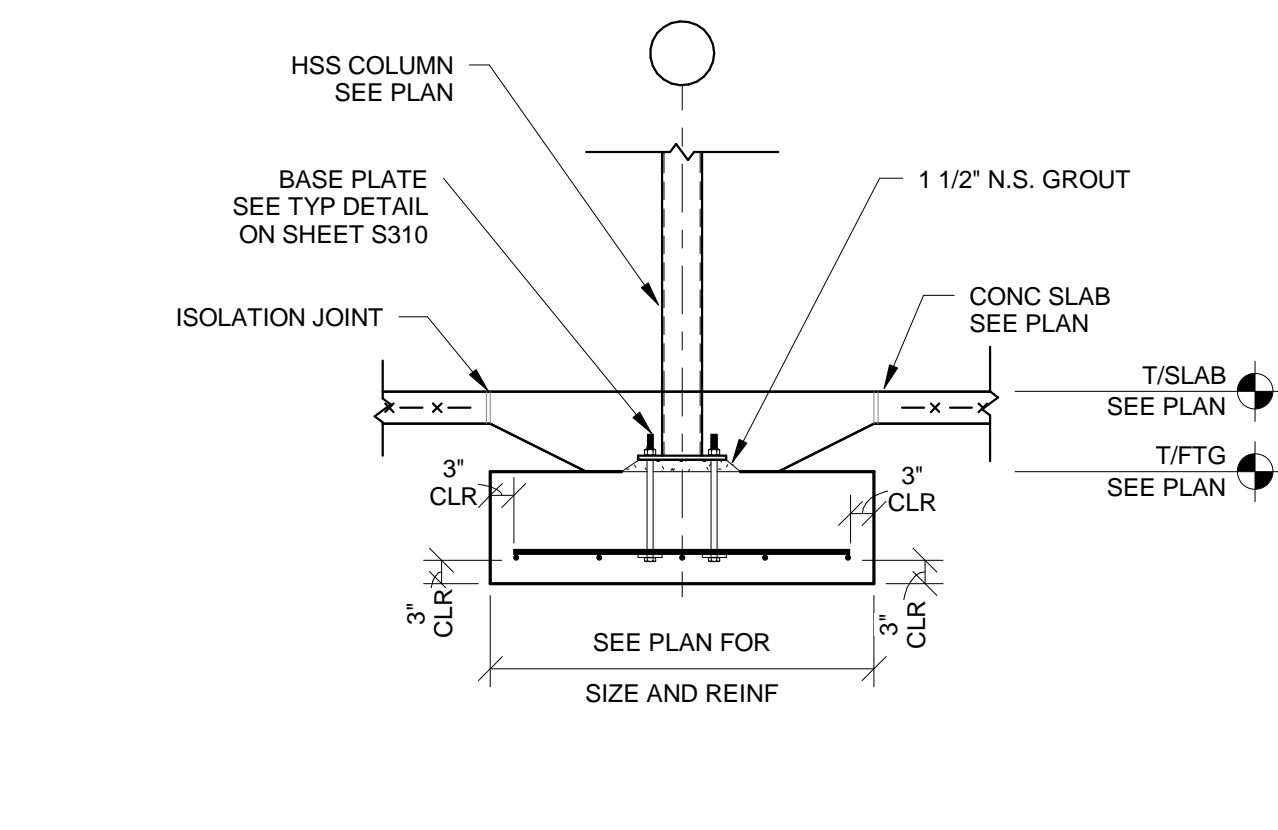

SECTION 4
SCALE 1/2" = 1'-0" S310

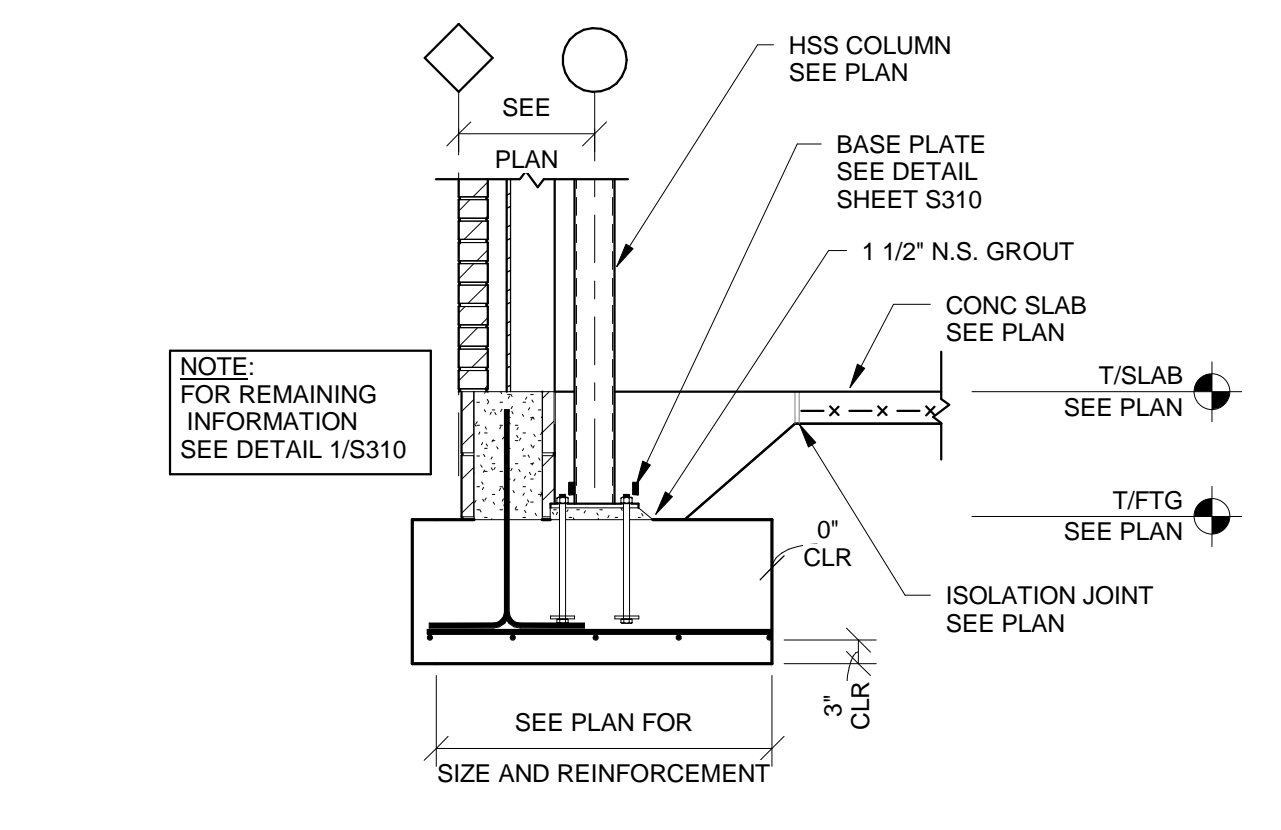

SECTION 5
SCALE 1/2" = 1'-0" S310

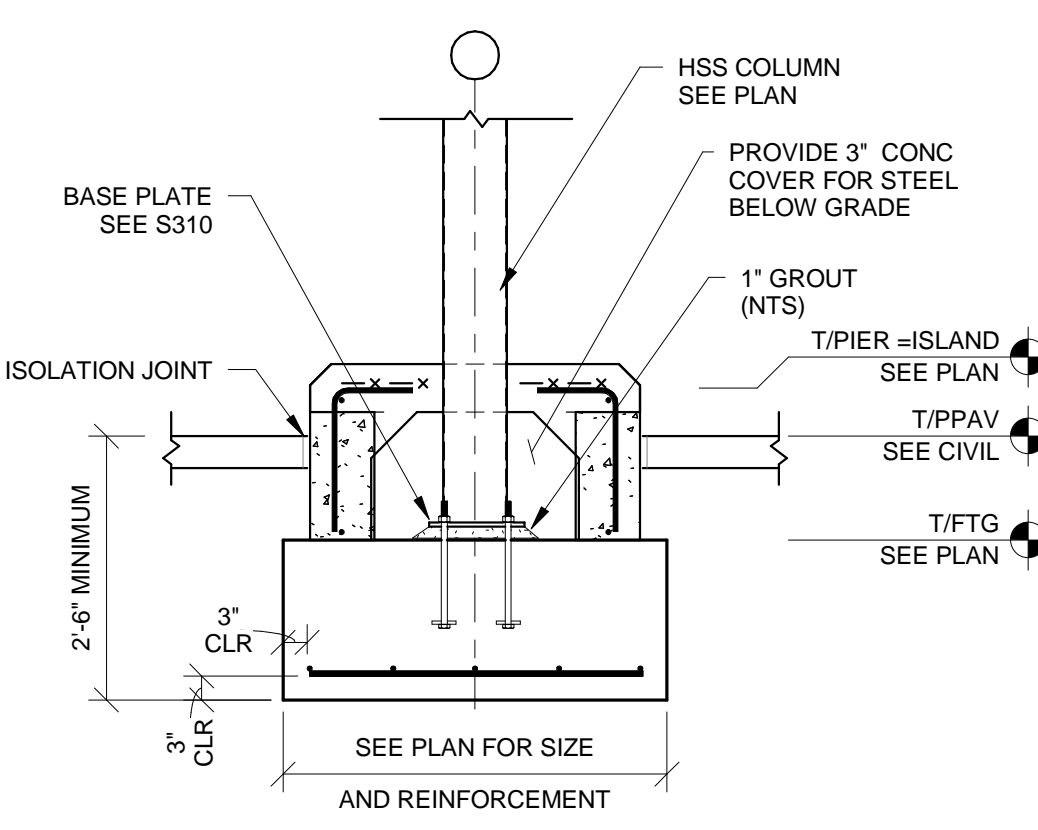

SECTION 6
SCALE 1/2" = 1'-0" S310

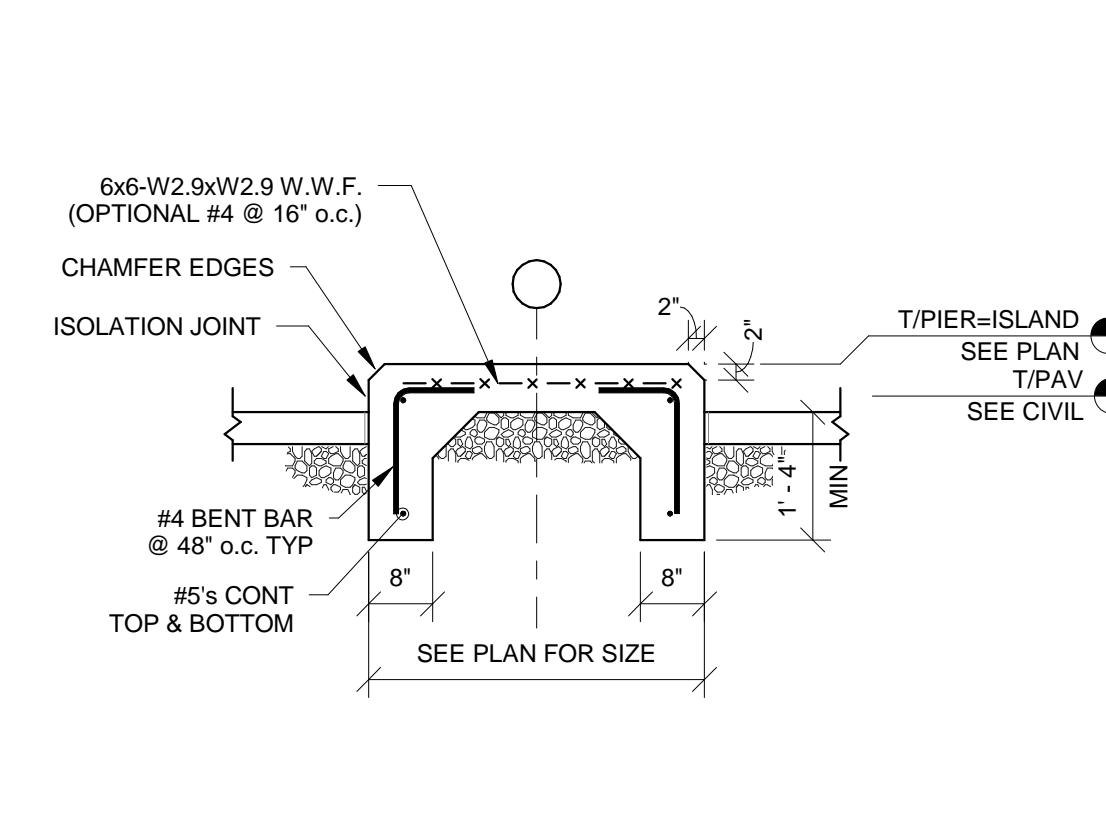

SECTION 7
SCALE 1/2" = 1'-0" S310

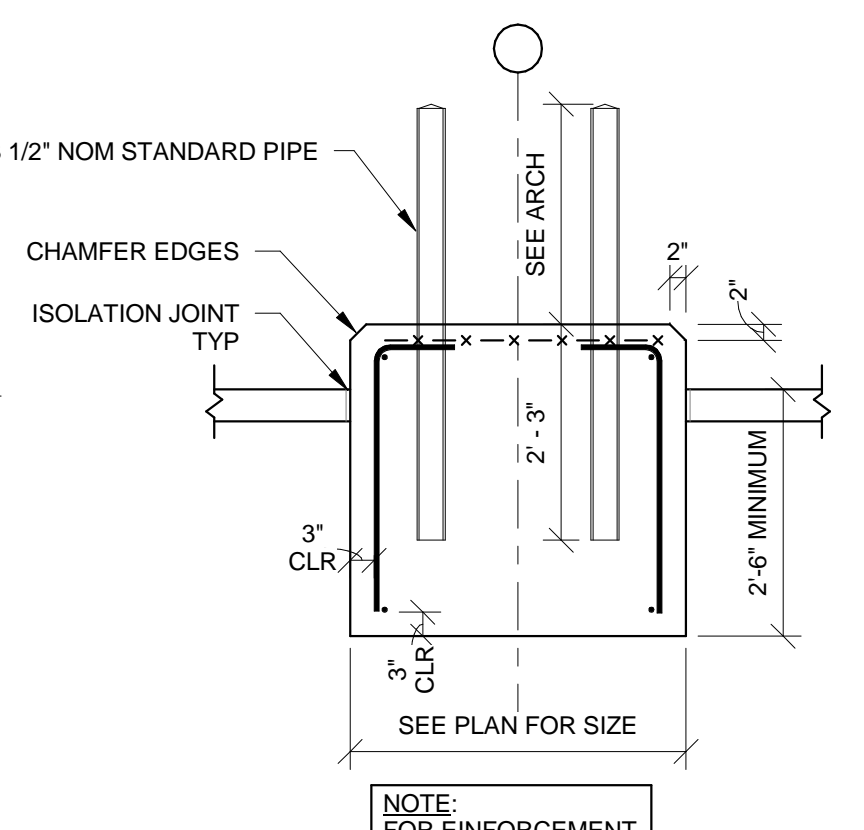

SECTION 8
SCALE 1/2" = 1'-0" S310

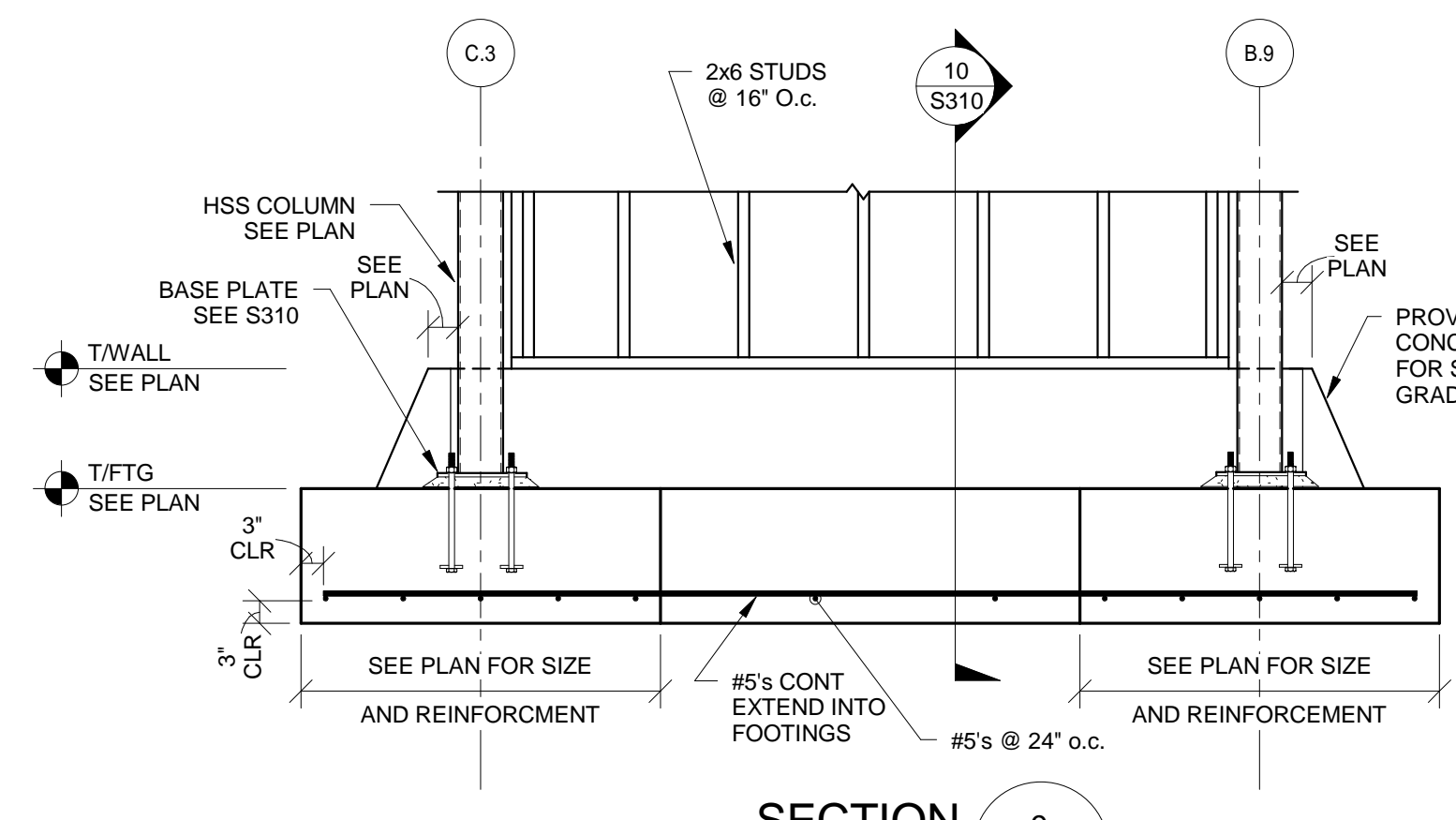

SECTION 9
SCALE 1/2" = 1'-0" S310

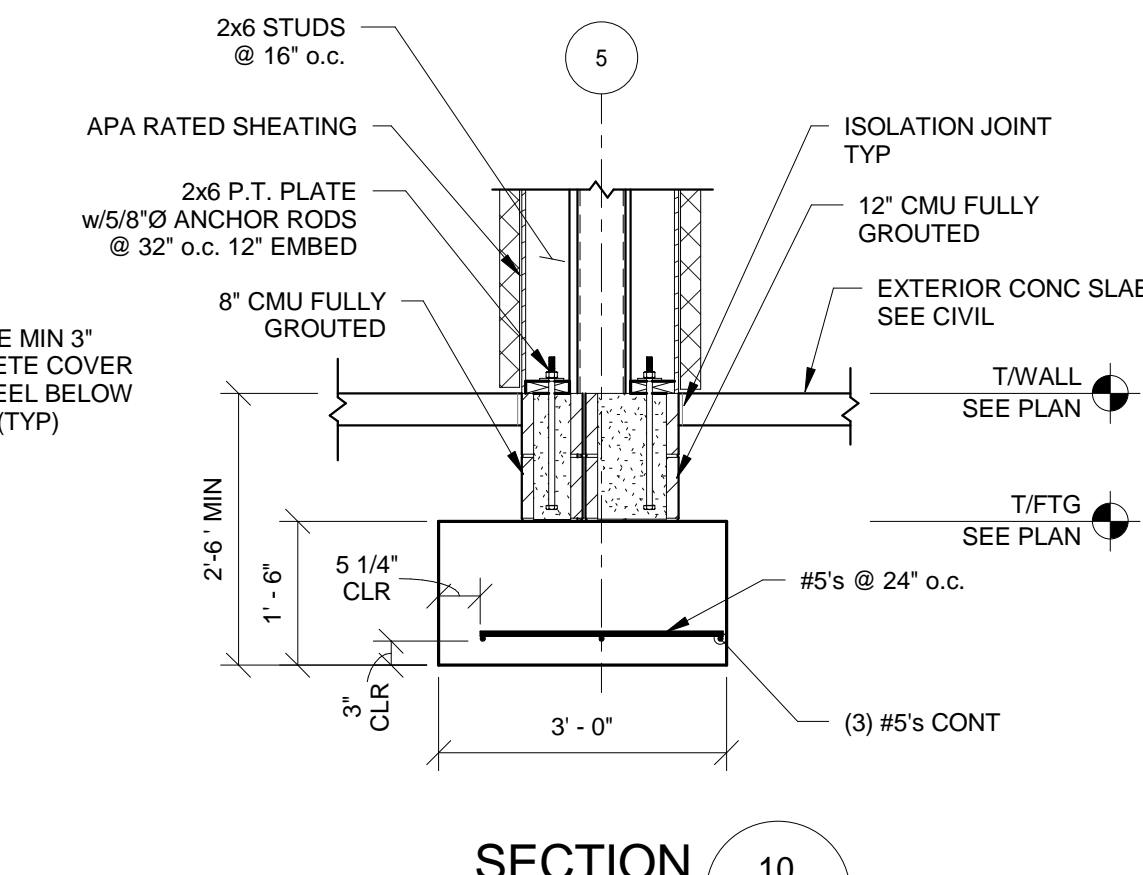

SECTION 10
SCALE 1/2" = 1'-0" S310

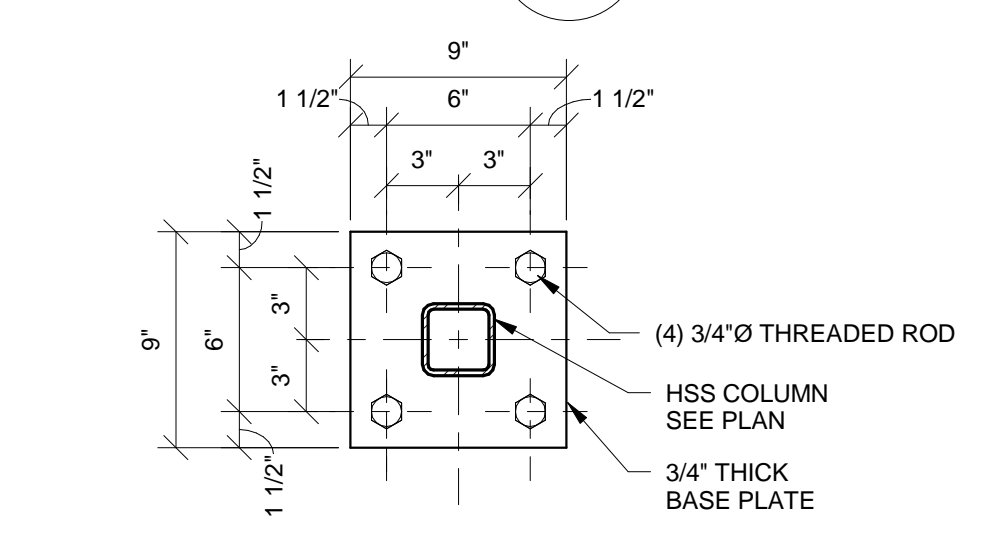

SECTION 11
SCALE 1 1/2" = 1'-0"

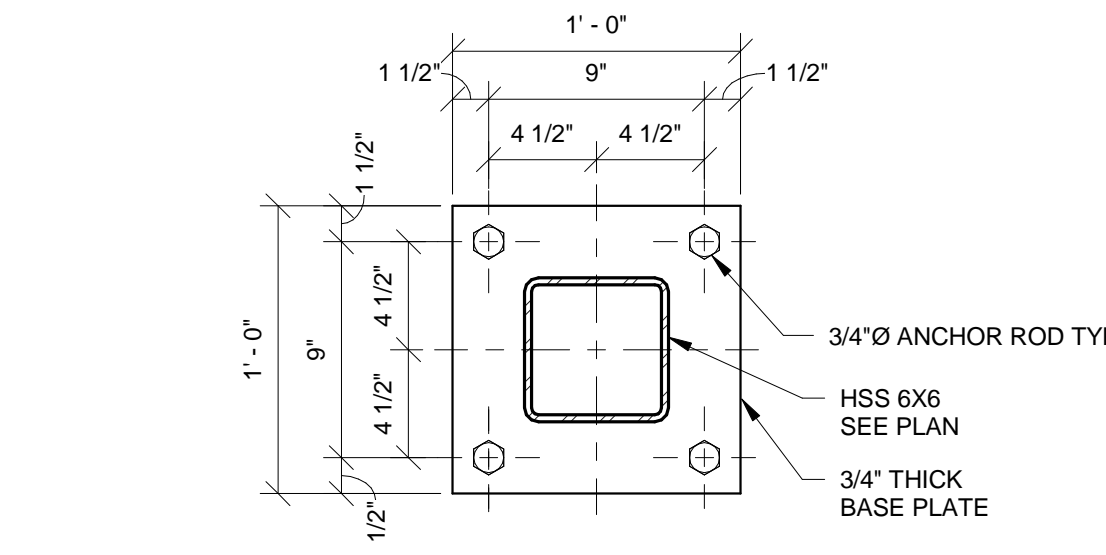

SECTION 12
SCALE 1 1/2" = 1'-0"

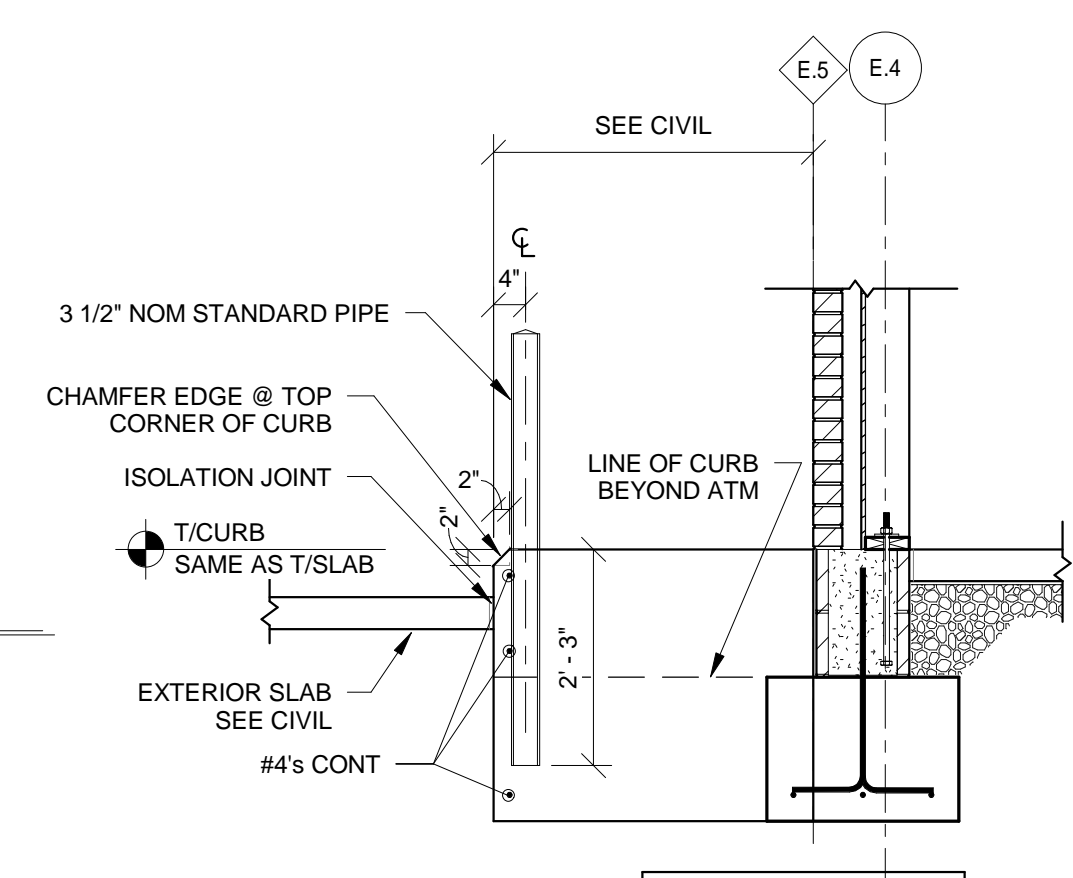

SECTION 13
SCALE 1/2" = 1'-0" S310

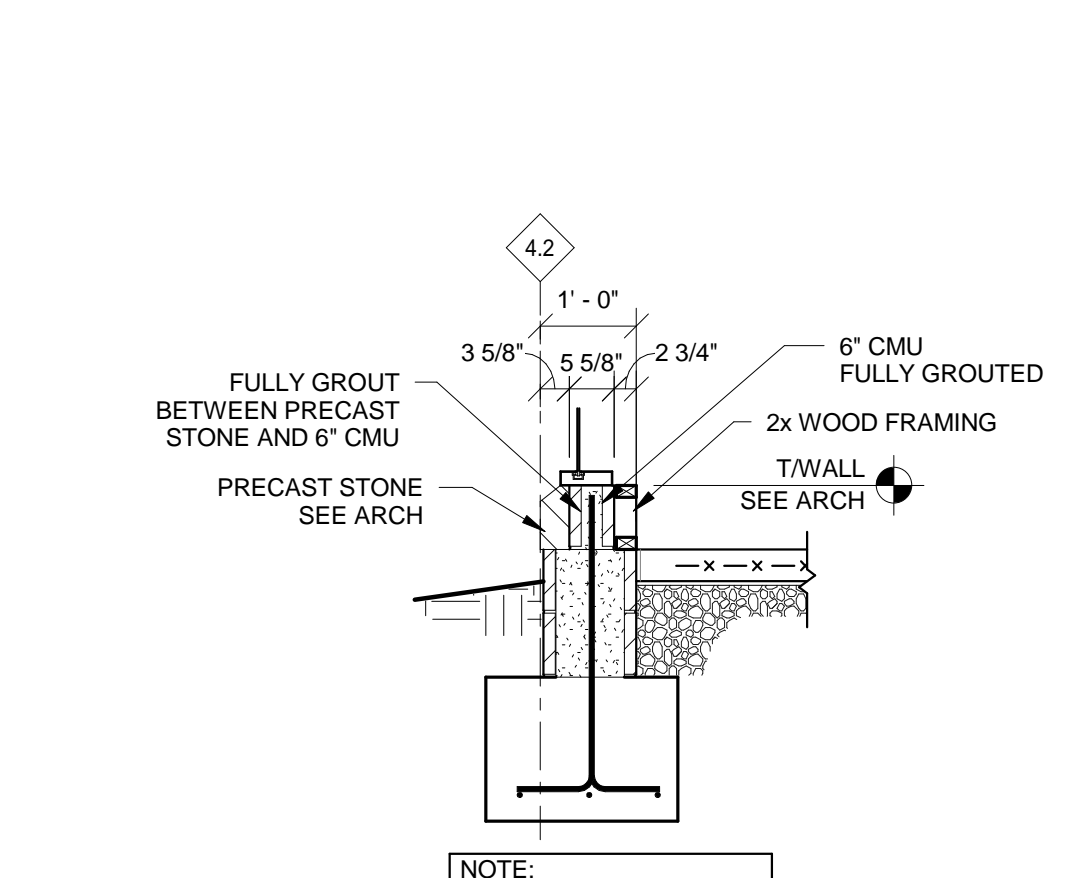

SECTION 14
SCALE 1/2" = 1'-0" S310

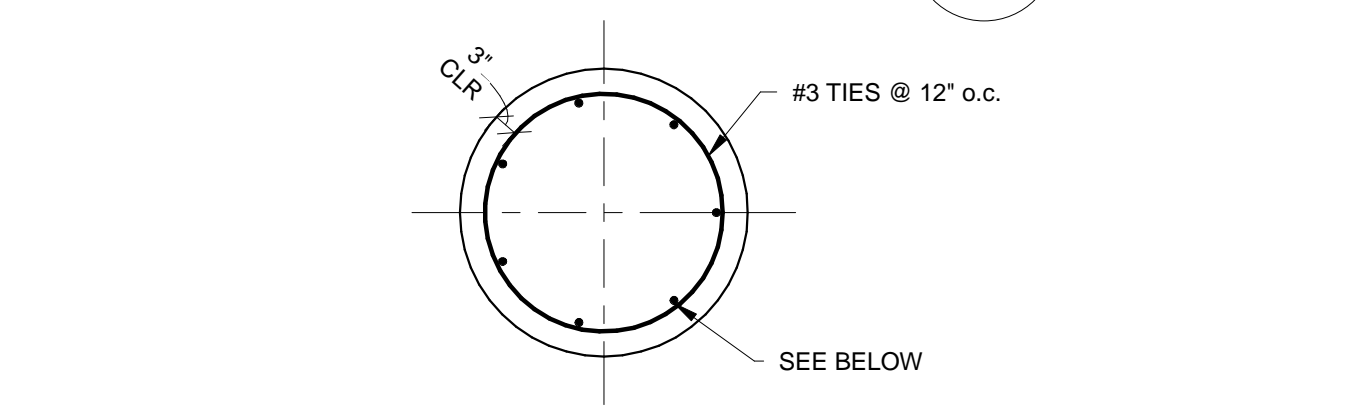

SECTION 15
SCALE N.T.S.

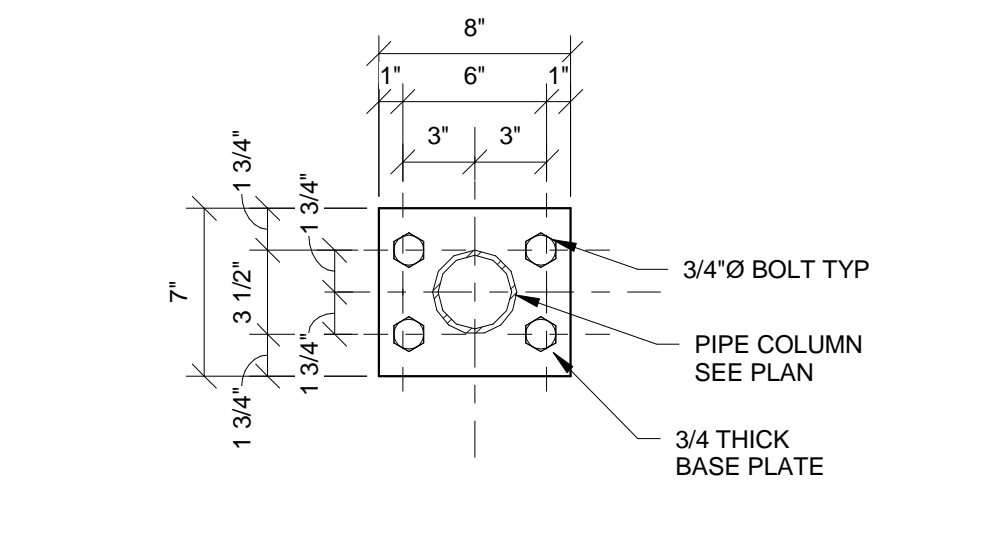

SECTION 16
SCALE 1 1/2" = 1'-0"

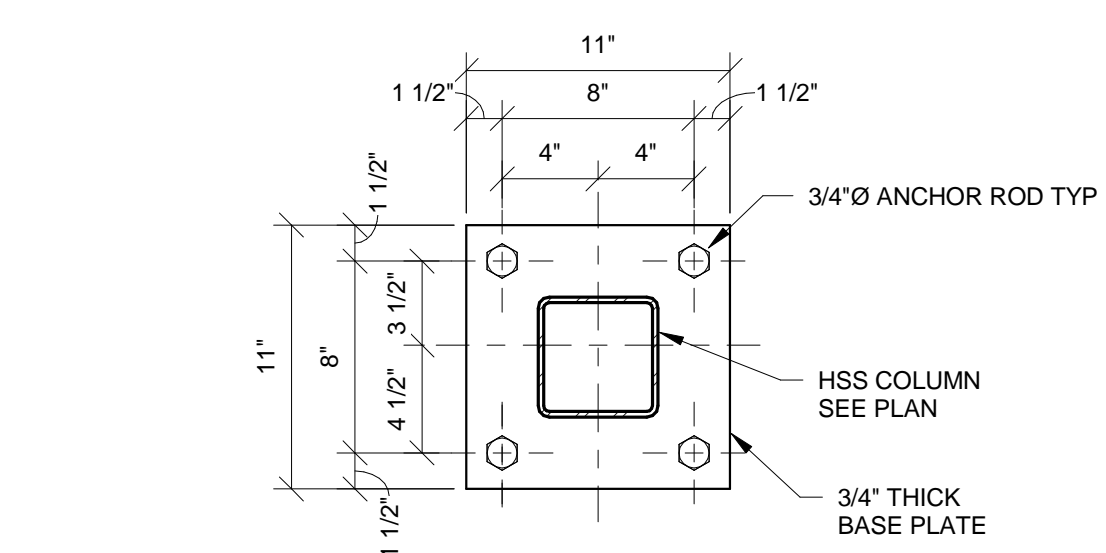

SECTION 17
SCALE 1 1/2" = 1'-0"

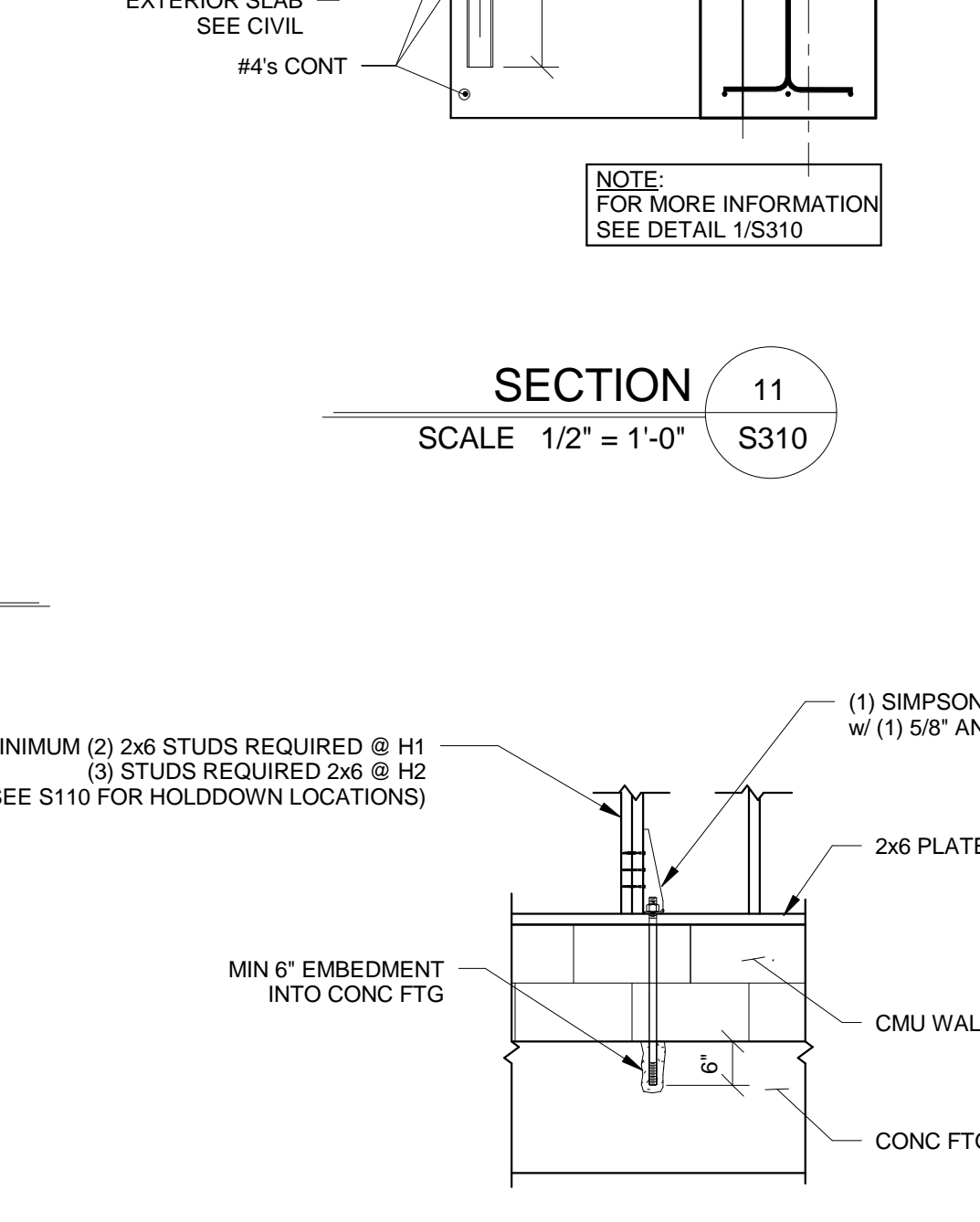

SECTION 18
SCALE 1/2" = 1'-0"

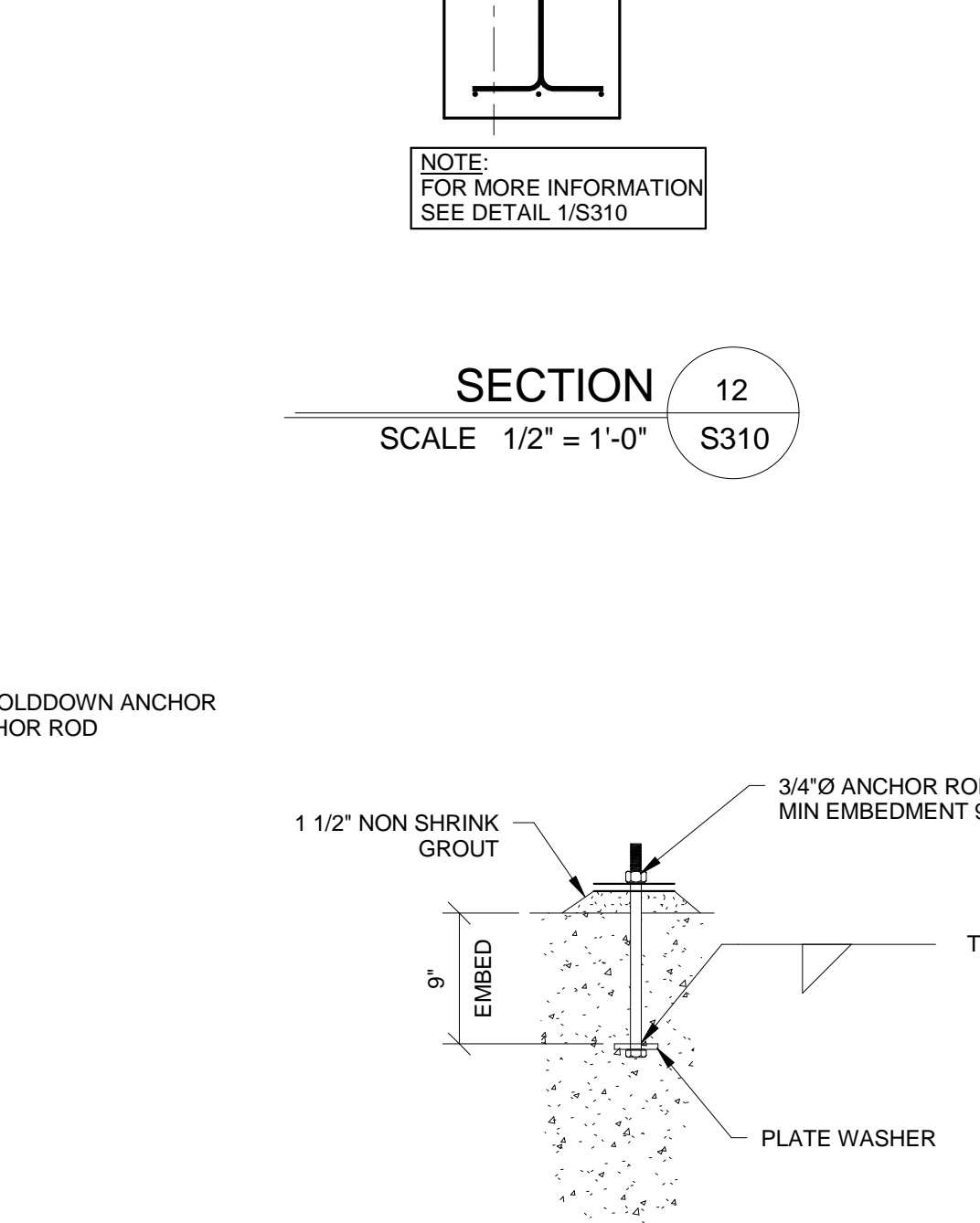

SECTION 19
SCALE 1" = 1'-0"

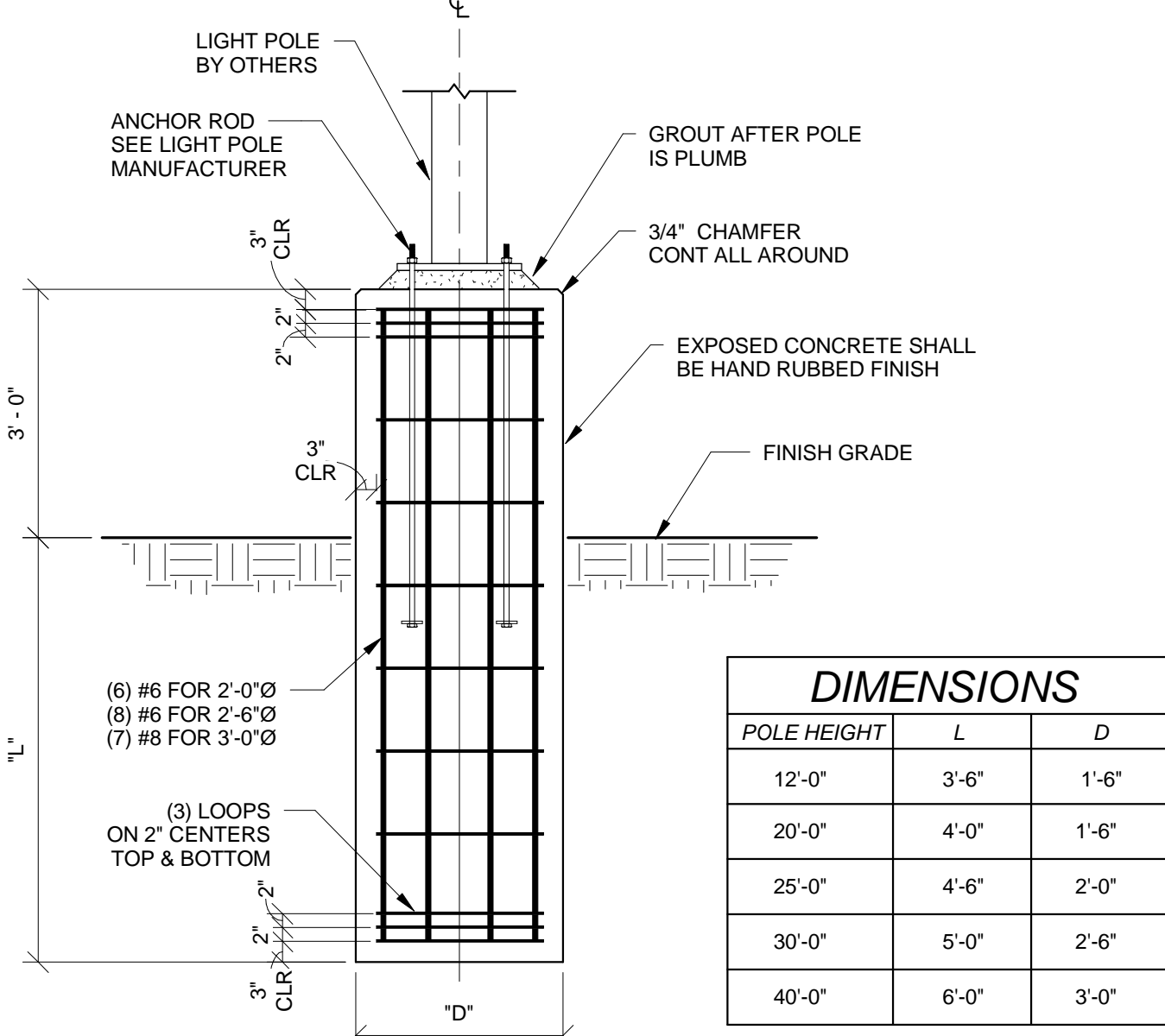

SECTION 20
SCALE 1/2" = 1'-0"

DIMENSIONS		
POLE HEIGHT	L	D
12'-0"	3'-6"	1'-6"
20'-0"	4'-0"	1'-6"
25'-0"	4'-6"	2'-0"
30'-0"	5'-0"	2'-6"
40'-0"	6'-0"	3'-0"

- NOTES:**
- THIS POLE BASE SHALL BE USED WHERE POLE IS IN TRAFFIC AREA NOT PROTECTED BY CURB OR OTHER BARRIER.
 - PLACE CONCRETE THE SAME DAY BASE IS DRILLED.
 - USE SONOTUBE FORM ABOVE GRADE AND EXTEND TO 6" BELOW GRADE.
 - VERIFY ANCHOR BOLT LOCATIONS WITH MANUFACTURER'S TEMPLATE PRIOR TO BASE CONSTRUCTION.
 - SEE ELECTRICAL DRAWINGS FOR CONDUIT INFORMATION; NOT SHOWN HERE.

K4 ARCHITECTURE, LLC
 555 Gest Street
 Cincinnati, Ohio 45203
 Tel: (513) 455-5005
 Fax: (513) 455-5008
 Webpage: www.k4places.com
 Email: k4arch@k4places.com

PROPOSED BANKING CENTER FOR:
first financial bank
 Shelbyville Branch
 1850 MARKETPLACE Blvd.
 SHELBYVILLE, INDIANA 46176

REVISIONS / SUBMISSIONS		
NO.	DESCRIPTION	DATE
1	PERMIT AND BID	02/22/10

Structural Consultants
ADVANTAGE GROUP ENGINEERS, INC.
 660 Lincoln Avenue, Suite 305
 Cincinnati, Ohio 45206
 Ph: (513) 396-8900
 FAX: (513) 396-8903

FOUNDATION SECTIONS
 Drawn By: GB/BR
 Scale: AS SHOWN
 Job No.: 09131.17

S310