

THIS DOCUMENT, AND THE IDEAS AND DESIGNS INCORPORATED HEREIN, IS THE PROPERTY OF K4 ARCHITECTURE, L.L.C. AND IS NOT TO BE USED, IN WHOLE OR IN PART, FOR ANY OTHER PROJECT WITHOUT THE WRITTEN AUTHORIZATION OF K4 ARCHITECTURE, L.L.C. COPYRIGHT 2009, K4 ARCHITECTURE, L.L.C. ALL RIGHTS RESERVED.

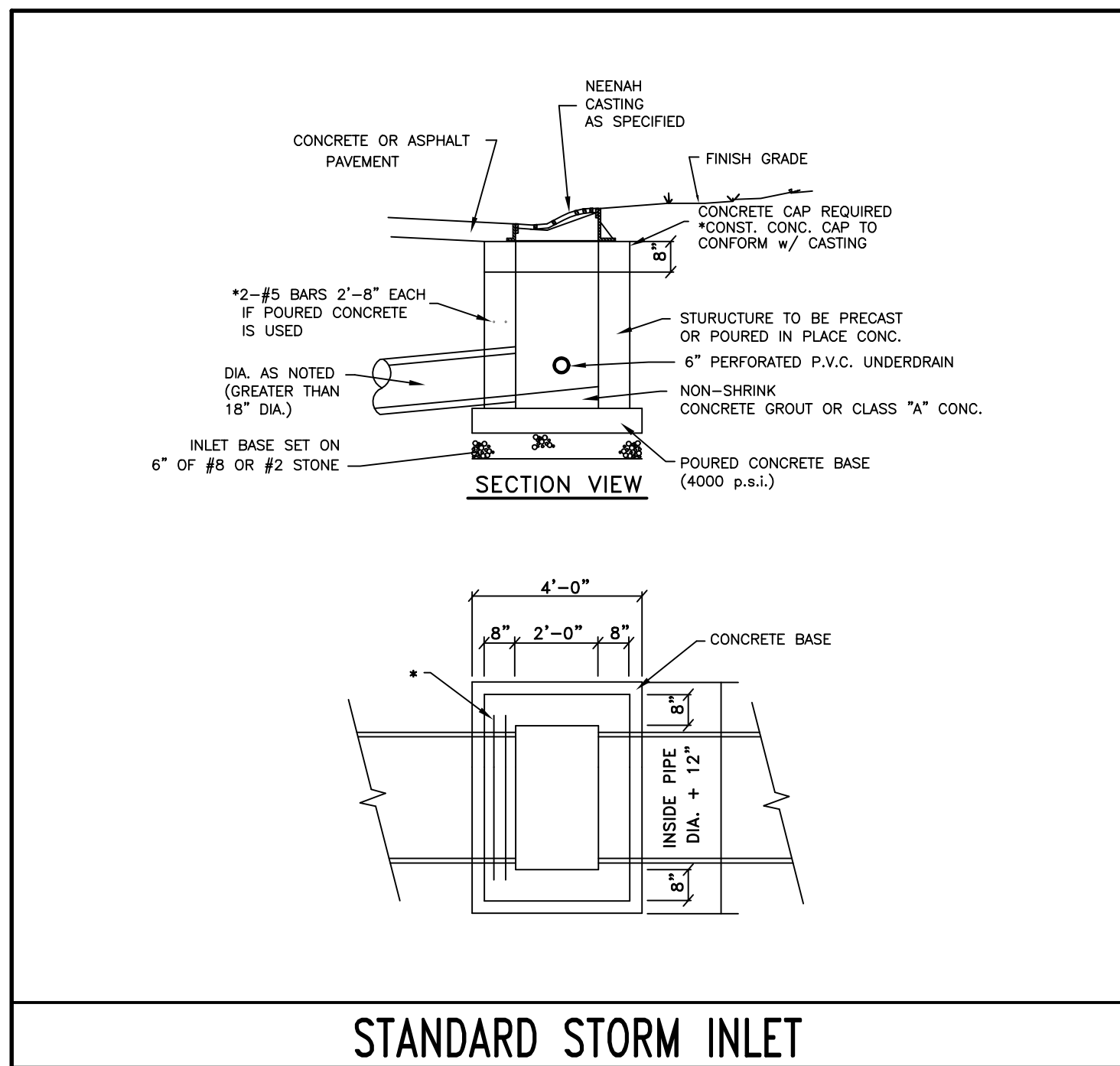

STANDARD STORM INLET

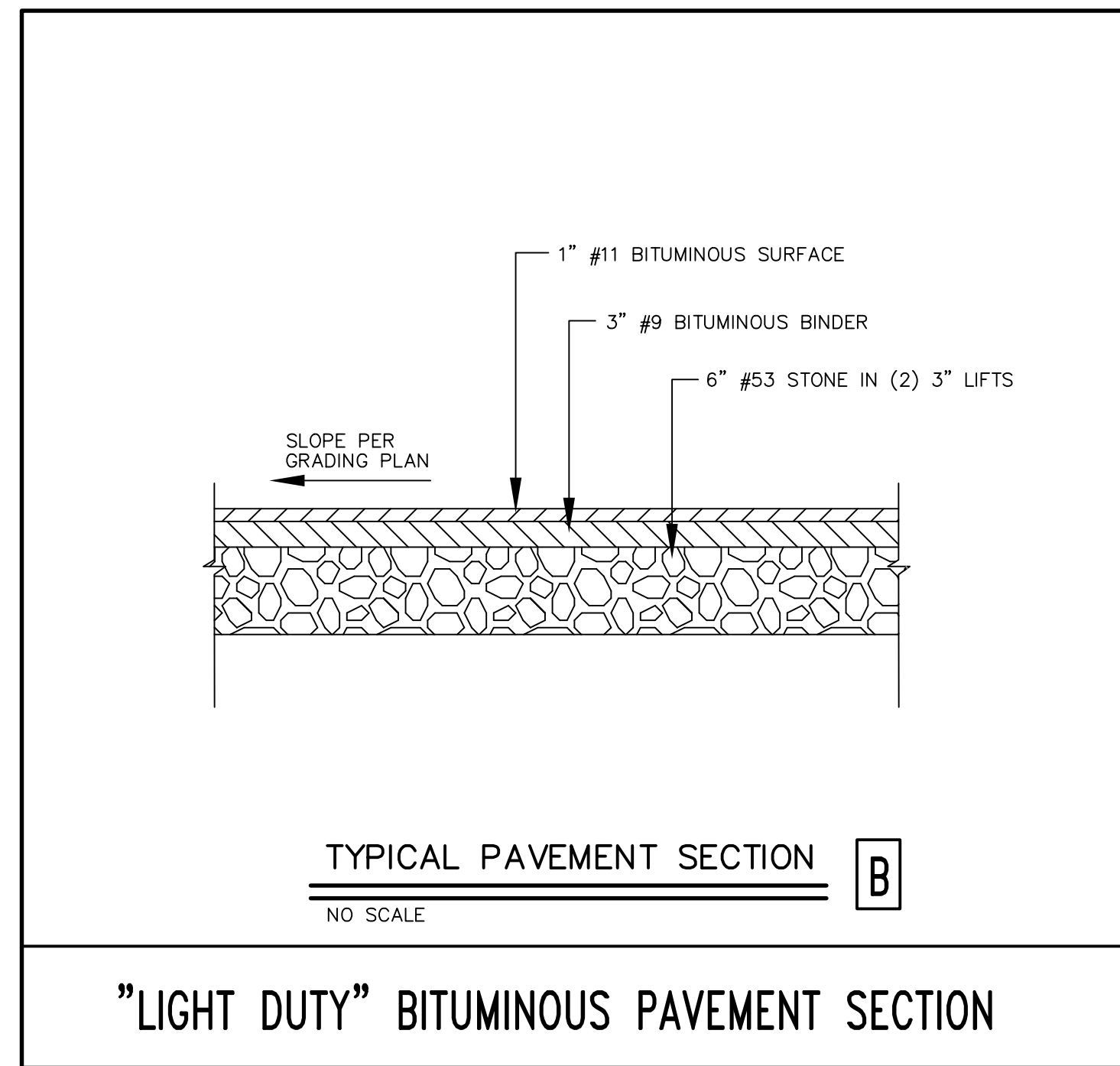

\"LIGHT DUTY\" BITUMINOUS PAVEMENT SECTION

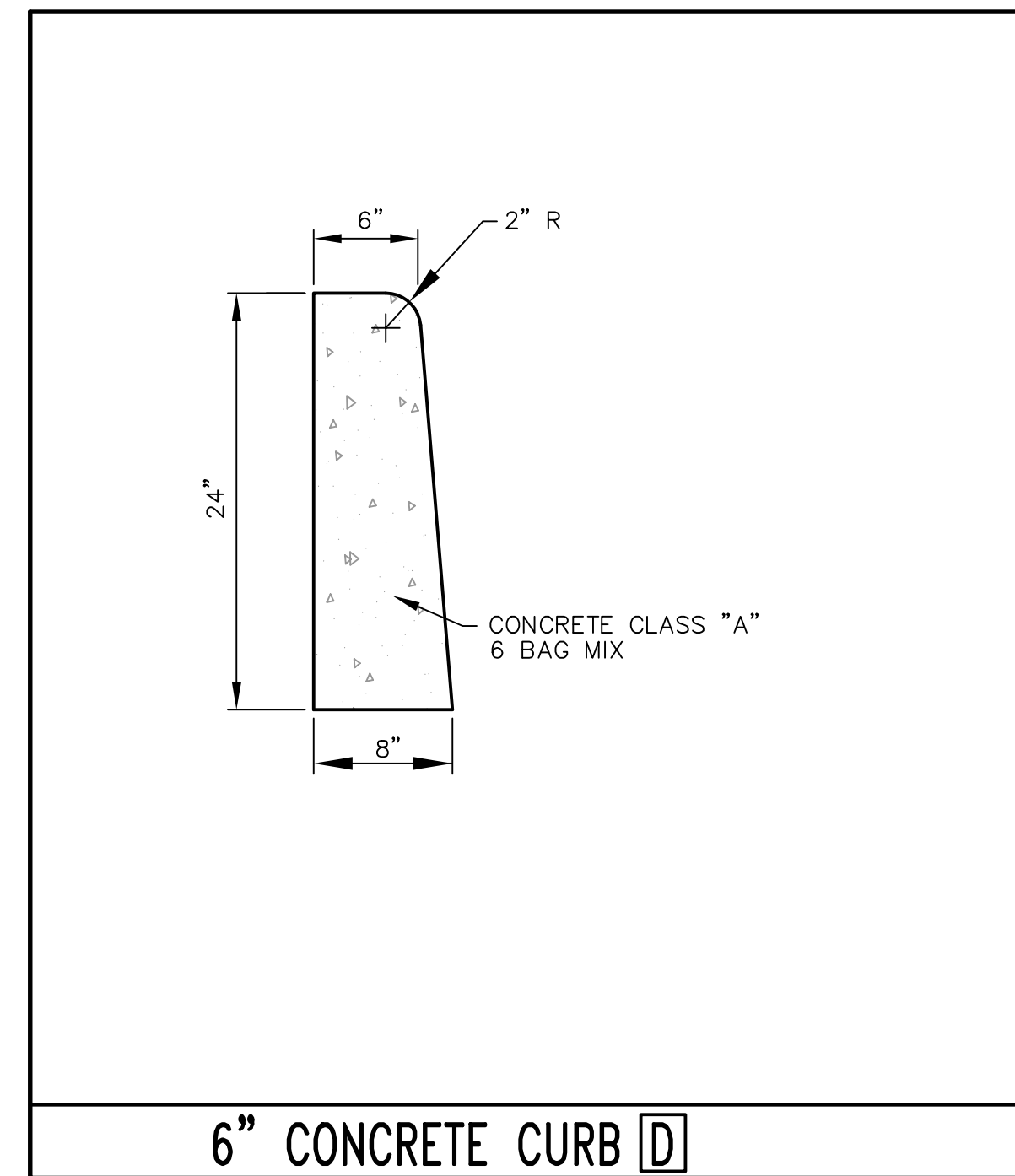

6\"/>

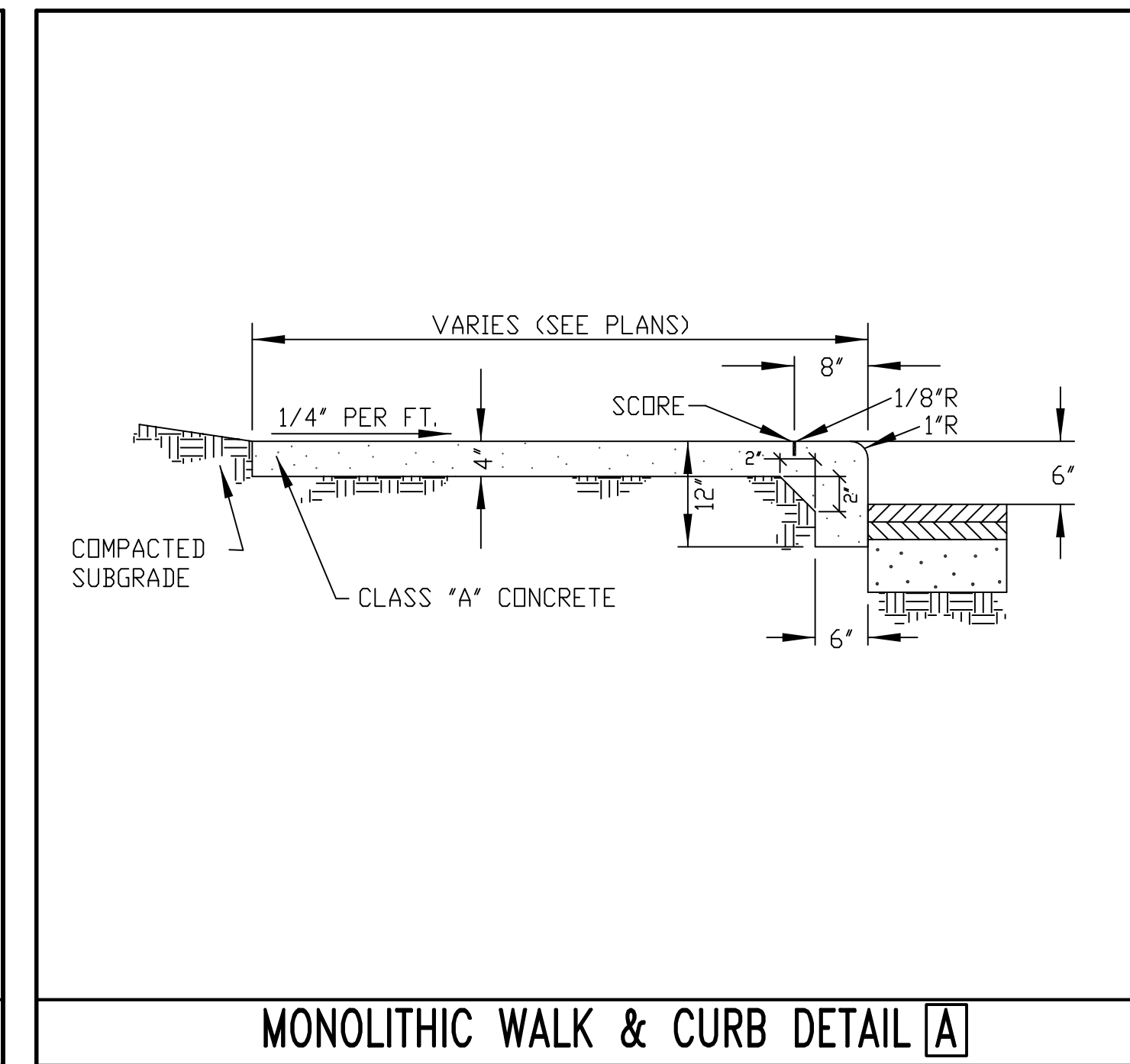

MONOLITHIC WALK & CURB DETAIL A

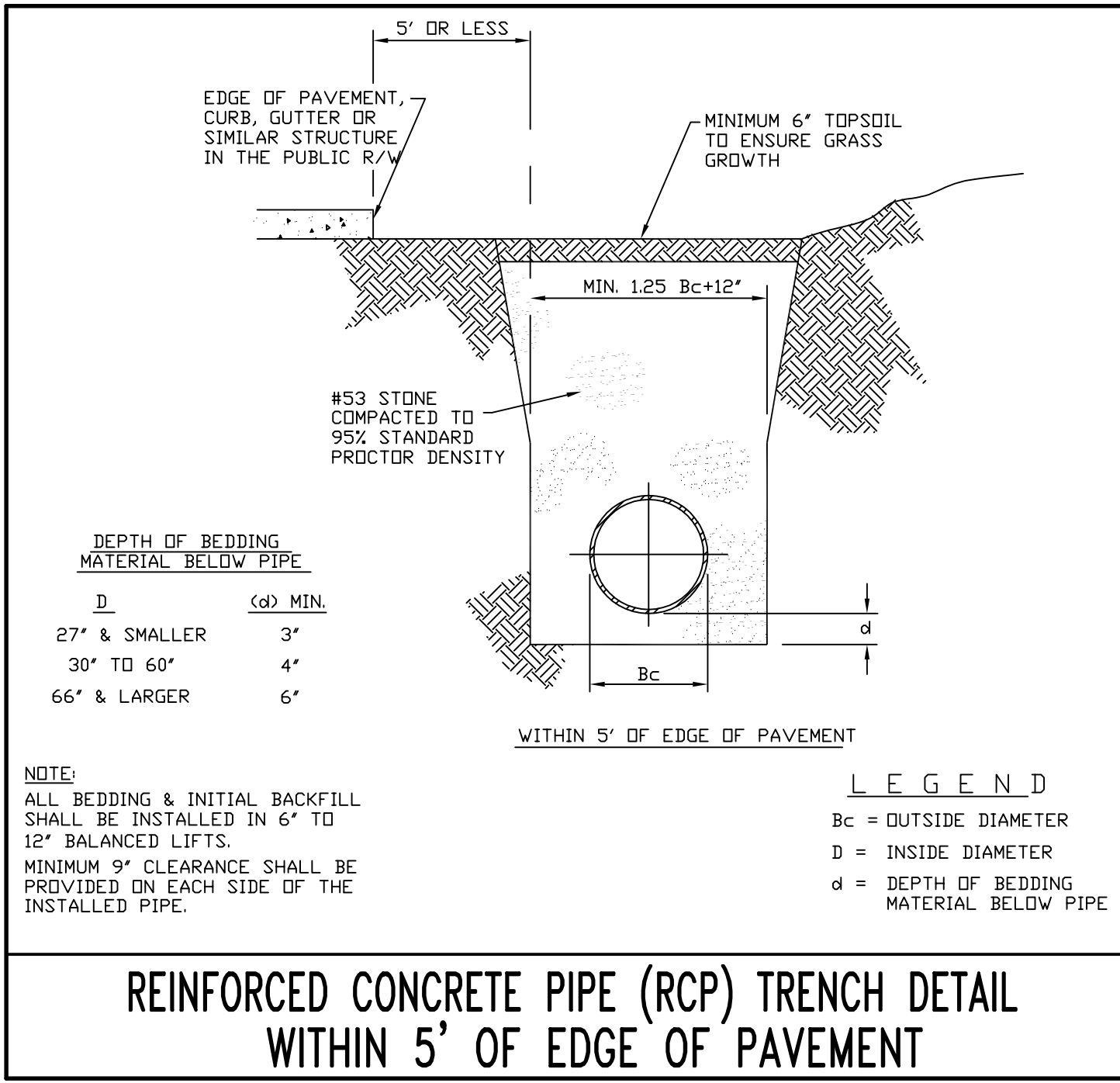

REINFORCED CONCRETE PIPE (RCP) TRENCH DETAIL WITHIN 5' OF EDGE OF PAVEMENT

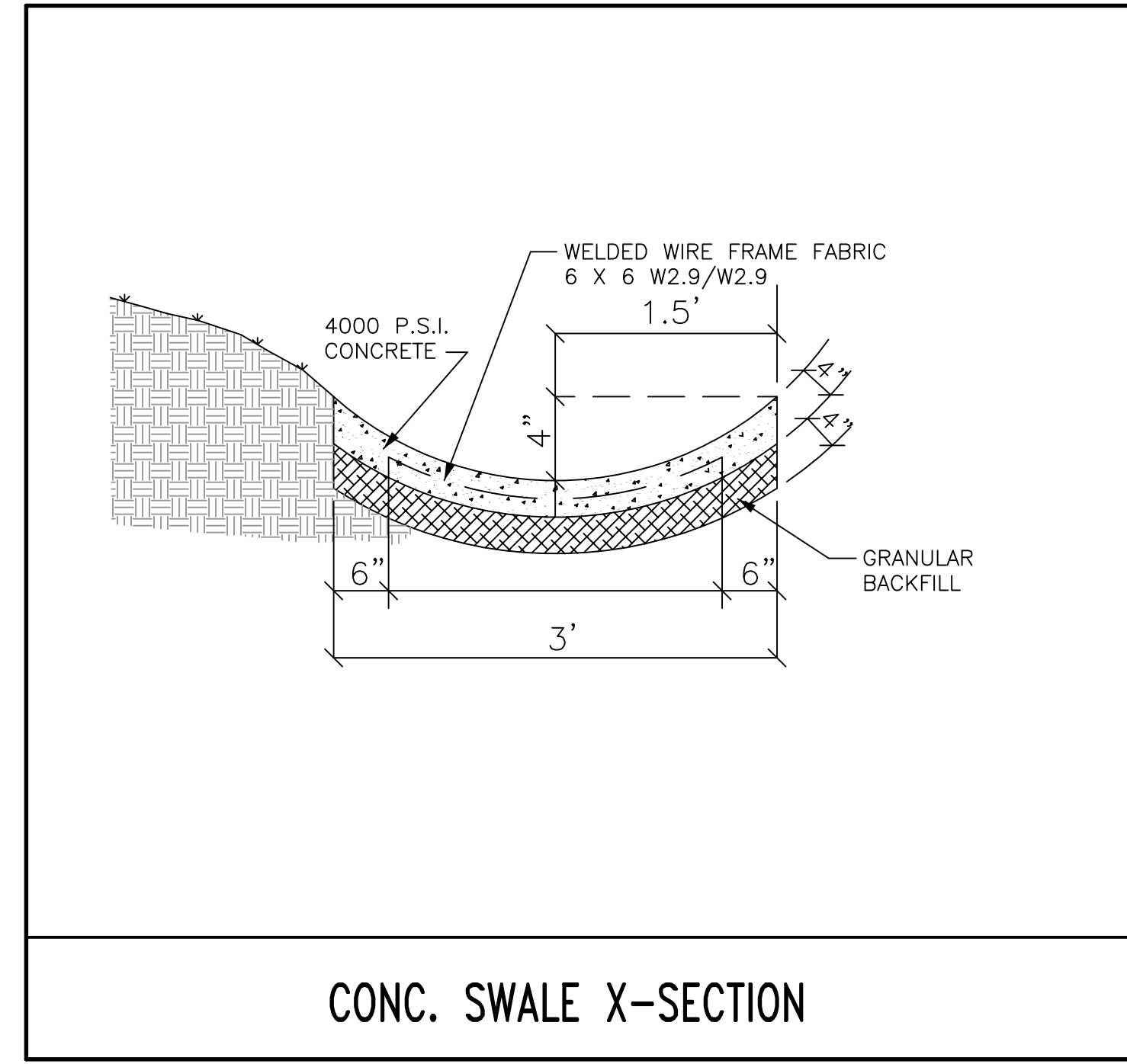

CONC. SWALE X-SECTION

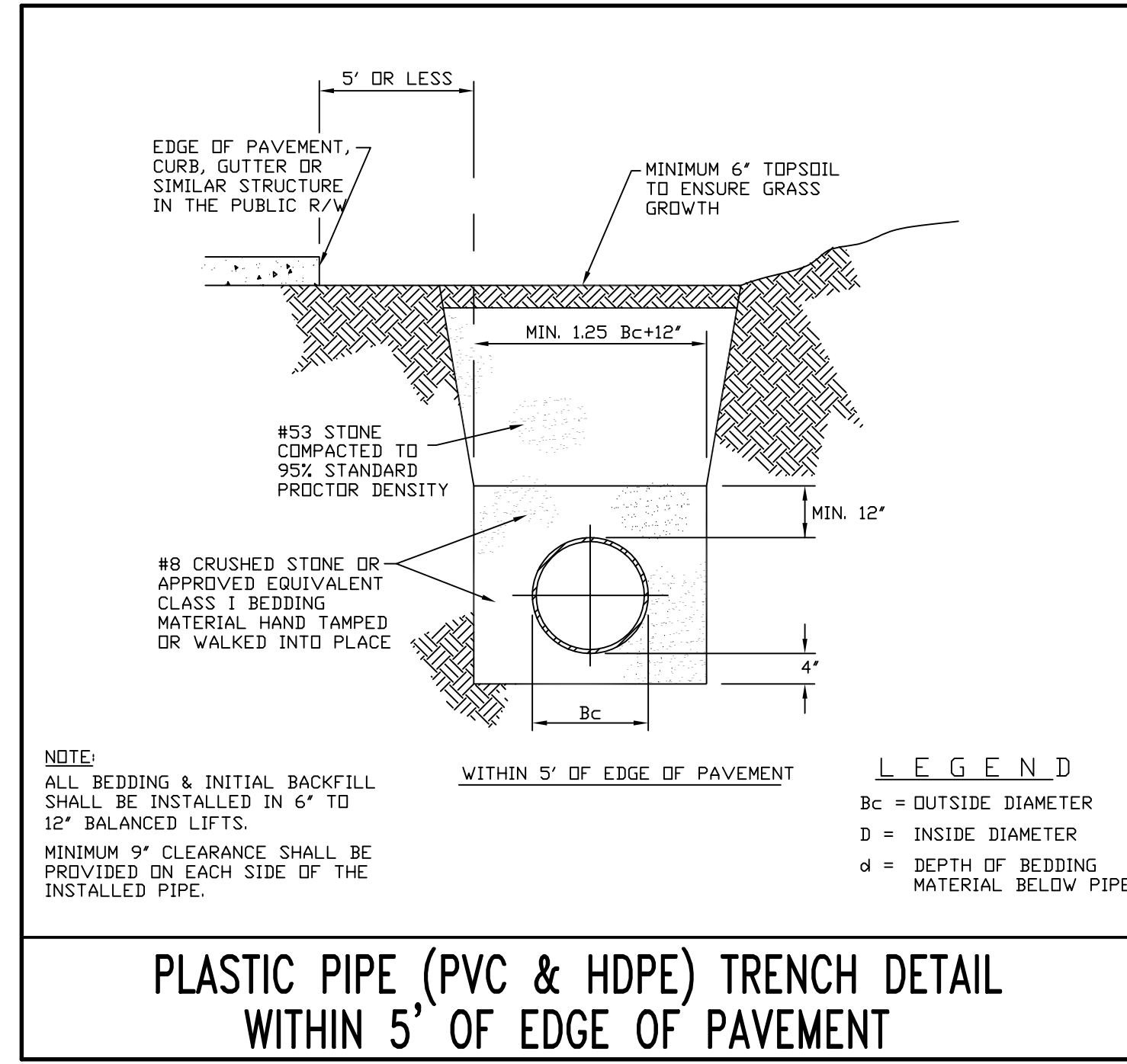

PLASTIC PIPE (PVC & HDPE) TRENCH DETAIL WITHIN 5' OF EDGE OF PAVEMENT

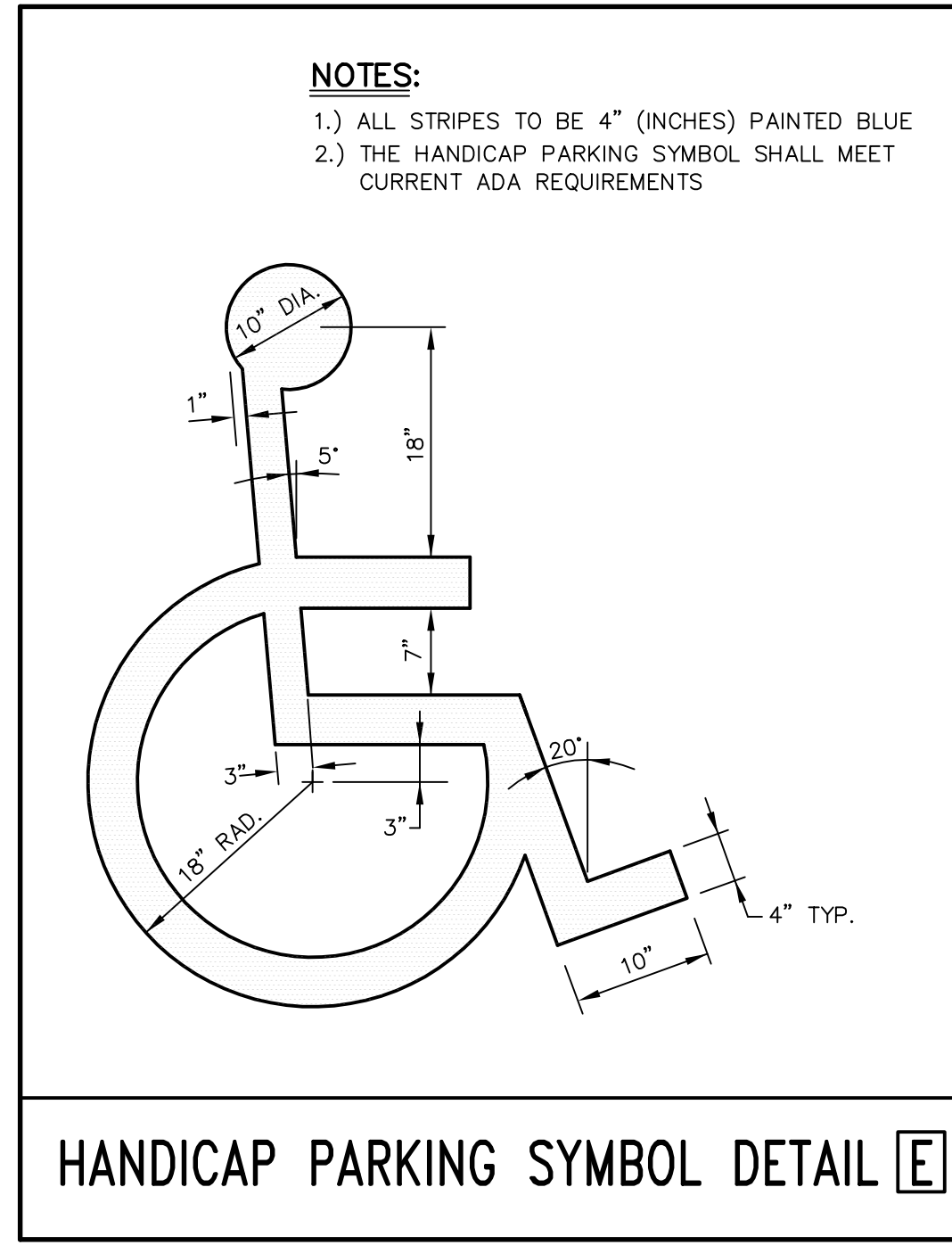

HANDICAP PARKING SYMBOL DETAIL E

- NOTES:**
- 1.) ALL STRIPES TO BE 4\" (INCHES) PAINTED BLUE
 - 2.) THE HANDICAP PARKING SYMBOL SHALL MEET CURRENT ADA REQUIREMENTS

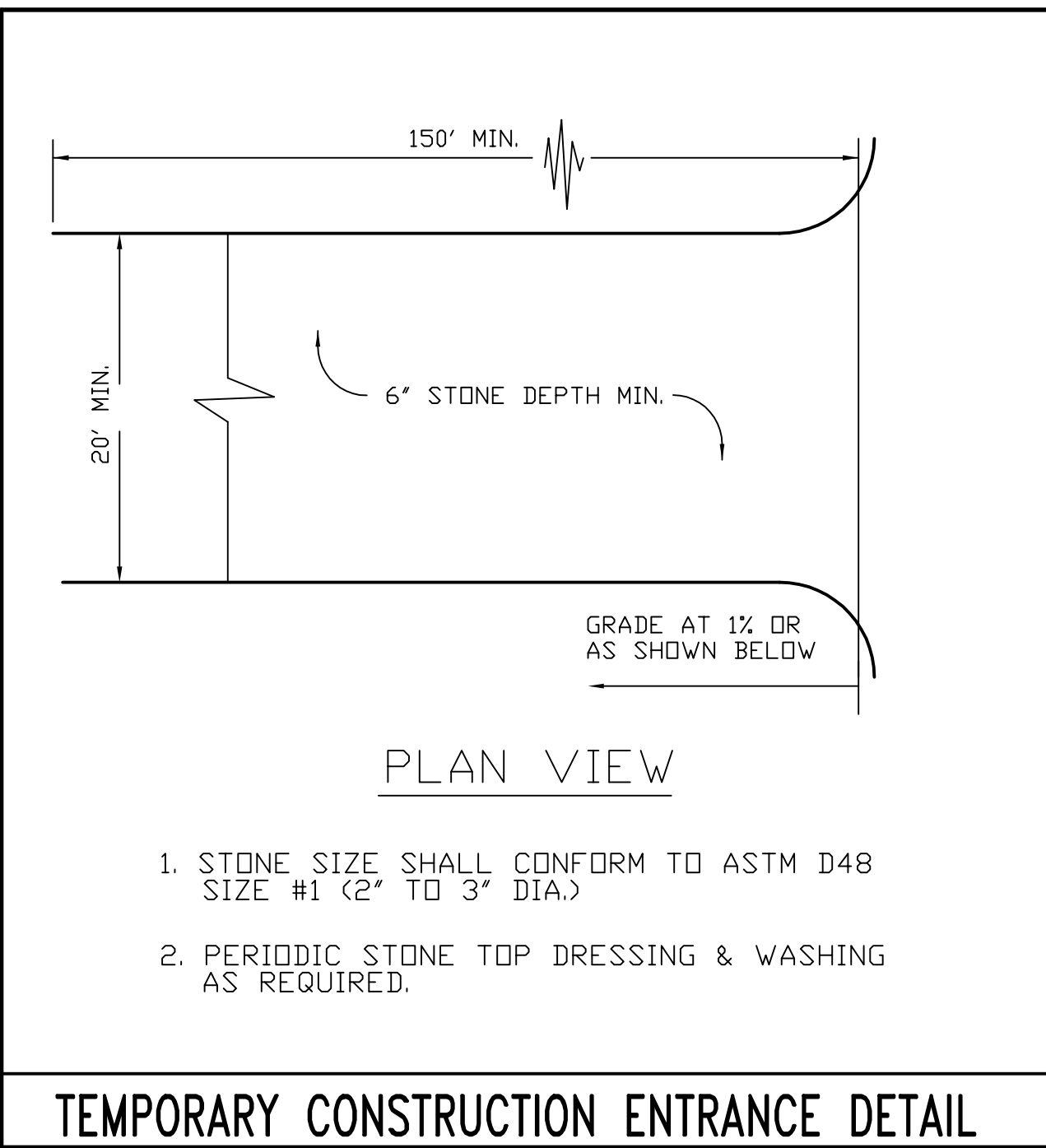

TEMPORARY CONSTRUCTION ENTRANCE DETAIL

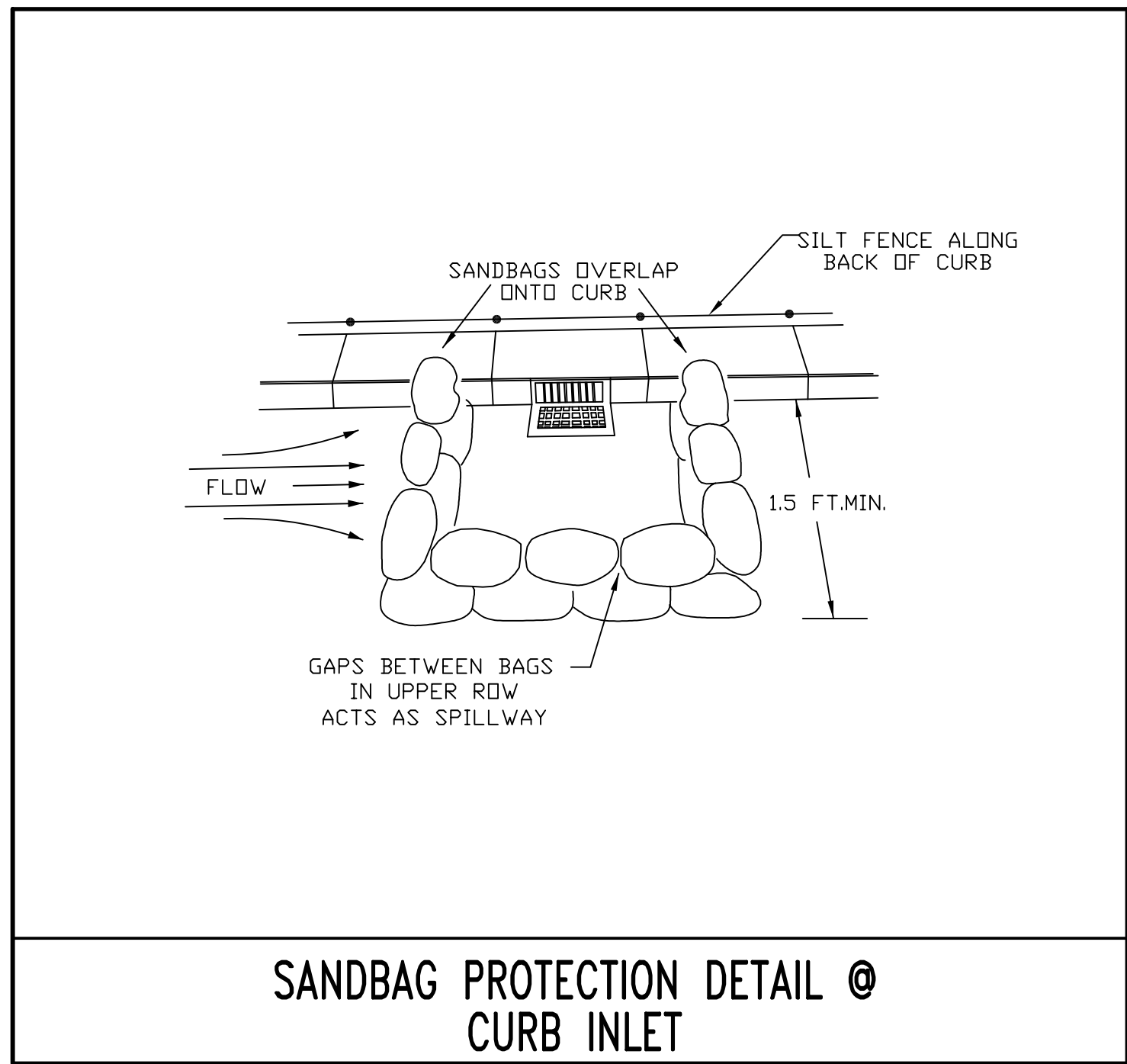

SANDBAG PROTECTION DETAIL @ CURB INLET

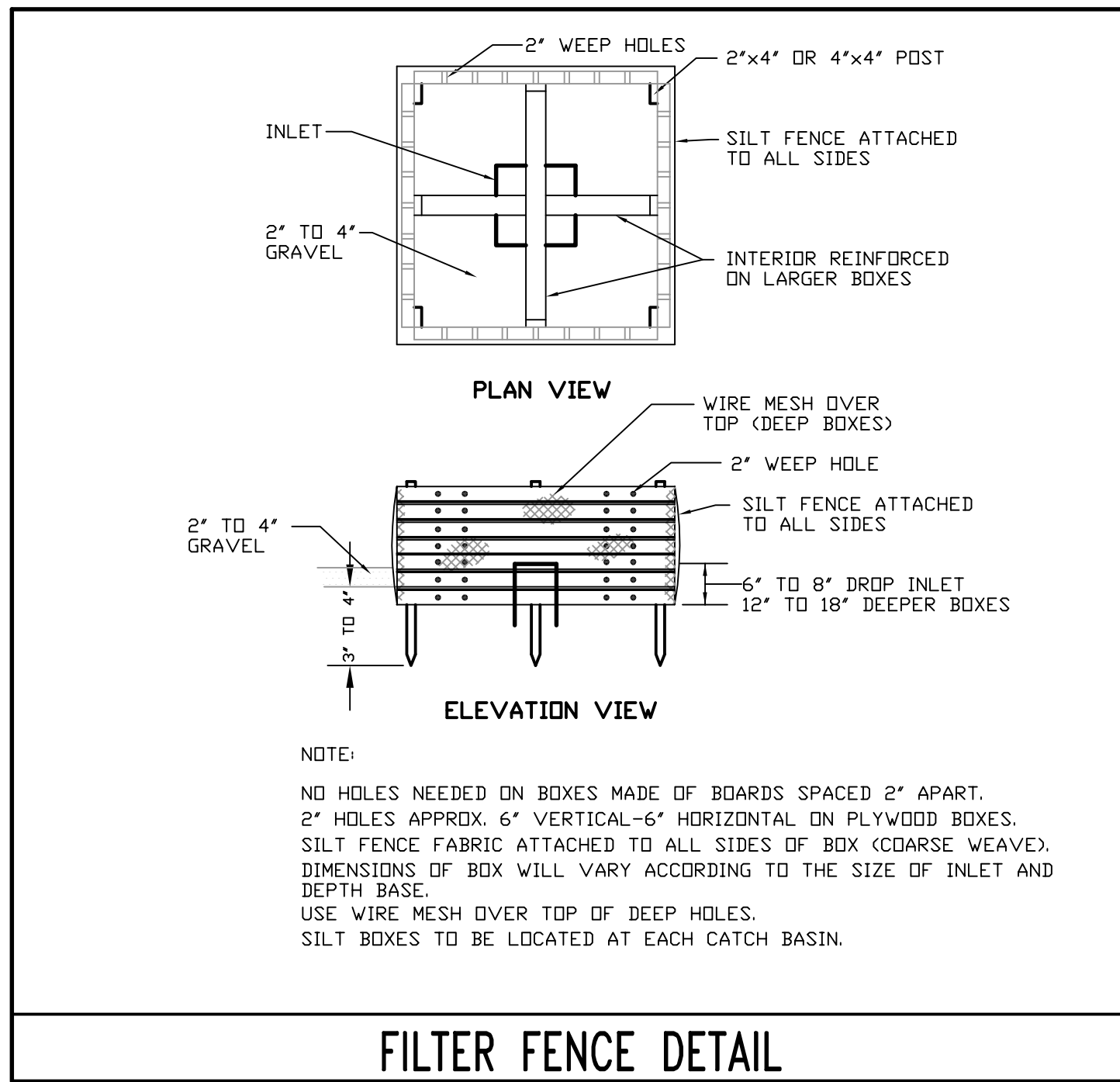

FILTER FENCE DETAIL

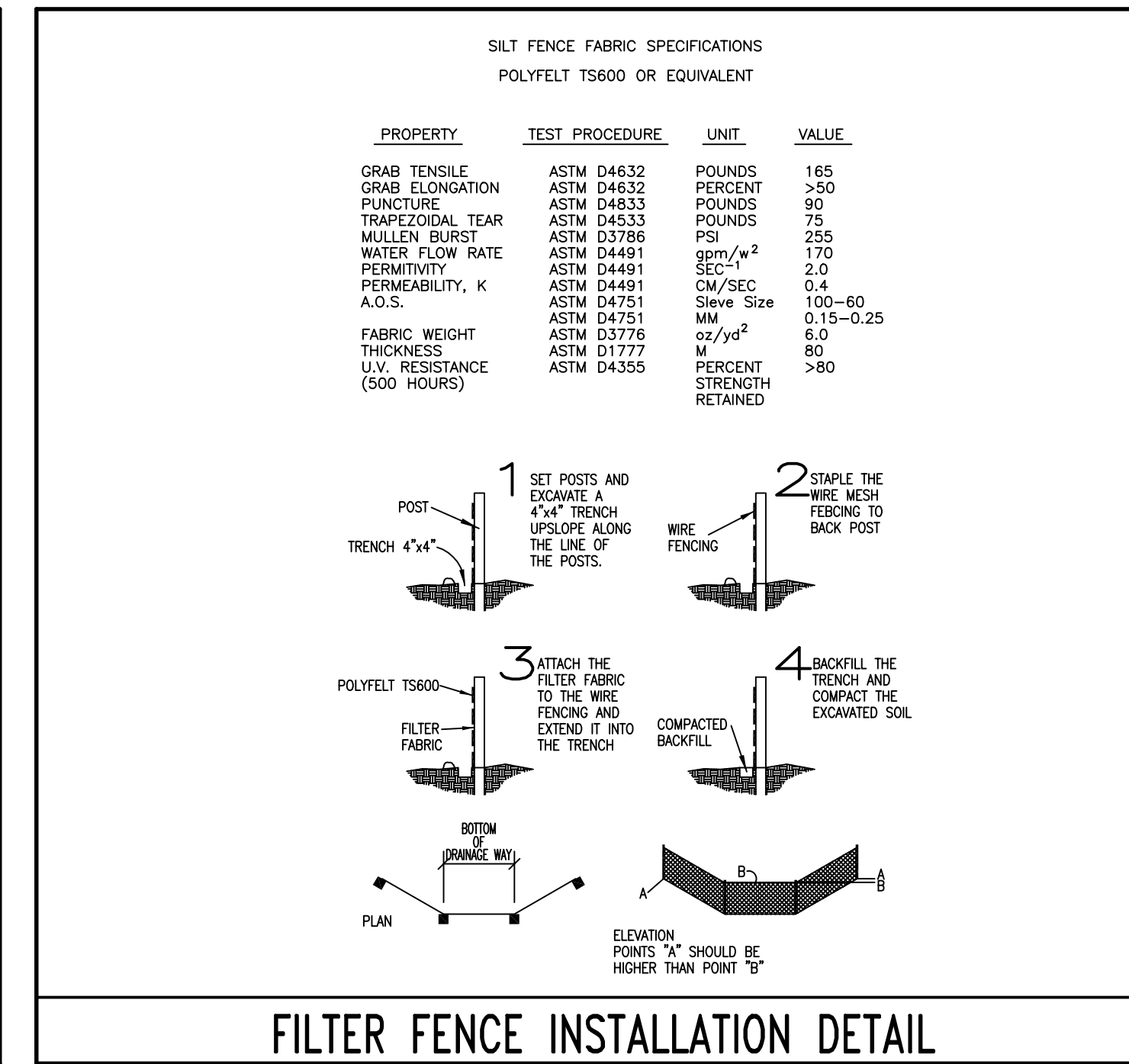

FILTER FENCE INSTALLATION DETAIL

SILT FENCE FABRIC SPECIFICATIONS
POLYFELT TS600 OR EQUIVALENT

PROPERTY	TEST PROCEDURE	UNIT	VALUE
GRAB TENSILE	ASTM D4632	POUNDS	185
GRAB ELONGATION	ASTM D4632	PERCENT	>50
PUNCTURE	ASTM D4833	POUNDS	90
TRAPEZOIDAL TEAR	ASTM D4533	POUNDS	75
MULLEN BURST	ASTM D3786	PSI	255
WATER FLOW RATE	ASTM D4481	gpm/ft ²	170
PERMITIVITY	ASTM D4491	SEC-1	2.0
PERMEABILITY, K	ASTM D4491	CM/SEC	0.4
A.O.S.	ASTM D4751	Stitch Size	100-80
FABRIC WEIGHT	ASTM D4751	MM	0.15-0.25
THICKNESS	ASTM D3776	oz/yd ²	6.0
U.V. RESISTANCE (500 HOURS)	ASTM D1777	M	80
	ASTM D4355	PERCENT STRENGTH RETAINED	>80

K4 ARCHITECTURE, L.L.C.
555 Gest Street
Cincinnati, Ohio 45203
Tel: (513) 455-5005
Fax: (513) 455-5008
Webpage: www.k4places.com
Email: k4crch@k4places.com

PROPOSED BANKING CENTER FOR:
first financial bank
Shelbyville Branch
ST. RD. 44 & MARKETPLACE Blvd
SHELBYVILLE, INDIANA 46176

REVISIONS / SUBMISSIONS

NO.	DESCRIPTION	DATE
1	TECH REVIEW	12/22/09
2	PLAN COMMISSION	1/11/10
3	FINAL	2/19/10

MAURER SURVEYING, INC.
3425 WEST COUNTY LINE ROAD
GREENWOOD INDIANA 46142
OFFICE - 317-851-3898
FAX 317-851-4099

LAND SURVEYING, LAND DEVELOPMENT & BUILDER'S SERVICES

GENERAL DETAILS

Drawn By: PM
Scale: 1\"/>

C07